



ELECTROMAGNETIC FLOW METER



CONTENT

ART Flange Electromagnetic Flow Meter

01

ART/T Tri-clamp Electromagnetic Flow Meter

11

ART/W Wafer Electromagnetic Flow Meter

16

ART/C Insertion Electromagnetic Flow Meter

21

ART/D Battery-powered Electromagnetic Flow Meter

29

ART/F Partially-filled Electromagnetic Flow Meter

36

ART/M Mini Electromagnetic Flow Meter

40

ART/J Slurry Electromagnetic Flow Meter

44

ART/R Reduced Bore Electromagnetic Flow Meter

50

ART Flange Electromagnetic Flow Meter



Description

ART magnetic flow meter, also known as electromagnetic flow meter or mag meter, is widely used because less obstruction, cost-effective and accurate measurement. Electromagnetic flow meter don't have any moving parts to wear down, reducing the need for maintenance or replacement. We offer flowmeters with a range of liners, electrodes, and sizes, which can meet various conductive liquids.



Compact



Remote



Industries

- Effluent Treatment Plant
- Sewage Treatment Plant Water Supply Scheme
- Steel & Aluminum Industries
- Food & Drug Industries
- Chemical & Fertilizer Industries
- Dairy Industries
- Sugar Industries
- Textile Processing Industries



Applications



Features

- Wide range of nominal diameters (DN3-3000)
- Independent of pressure, temperature, density and viscosity
- No moving parts, maintenance-free
- Automatic power failure recording function (optional)
- Built-in grounding electrodes
- Bi-directional flow measurement
- High accuracy 0.2% available
- Self-diagnosis function, empty pipe alarm, exciting alarm
- Support data record / bluetooth / wireless communication



Technical Data

Size	DN3-DN3000mm (1/8"-120")	
Accuracy	±0.5% of reading at flow velocity ≥ 0.5m/s, ±0.2% optional at flow velocity ≥ 0.5m/s	
Velocity	0.1~15 m/s	
Repeatability	≤0.17%	
Structure	Compact / remote, cable length 10m standard, 100m max	
Conductivity	> 5 μS/cm, demineralized water > 20 μS/cm	
Protection Grade	Transmitter: IP65 standard, IP67 optional	
	Sensor: IP65 standard, IP68 (submersible, only available for remote type)	
Electrode	SS316L, Hastelloy C, Hastelloy B, Titanium, Tantalum, Platinum-iridium	
Power Supply	85 ~ 250 VAC (50/60 Hz), 20 ~ 36 VDC	
Power Consumption	<20W	
Signal Output	Analog	4~20mA (load resistor 0~750Ω)
	Frequency	Forward & reverse flow output with a frequency range of 1~5000Hz
	Alarm	Two isolated open collector transistor (OCT) outputs for alarm signals
Communication	RS485 MODBUS RTU standard, HART, GPRS, PROFIBUS optional	
Display	LCD Display, 128X128mm, three lines, 4 buttons	
Ambient Temperature	-20°C~60°C	
Fluid Temperature	Compact: -20°C~80°C, Remote: -20°C~120°C	
Liner Material	PTFE (-20°C~150°C, DN15-DN1600)	
	FEP (-20°C~120°C, DN3-DN1800)	
	PFA (-20°C~160°C, DN3-DN800)	
	Polyurethane (-10°C~60°C, DN40-DN1600)	
	Neoprene (-10°C~80°C, DN40-DN3000)	
	Hard Rubber (-10°C~80°C, DN 40-DN3000)	
	Ceramic (-20°C~180°C, DN15-DN200)	
Flange Standard	DIN, ANSI, JIS	
Sensor Material	Measuring tube: SS304	
	Flange & housing: carbon steel (standard), SS304 / SS316 optional	
Transmitter Material	Aluminium alloy with epoxy painting	
Nominal Pressure	PN10 / PN16 / PN25 / PN40	DIN
	10K / 20K / 30 K	JIS
	150# / 300# / 600#	ANSI
	High pressure 42 MPa / ANSI 2500# can be customized	
Display	Instantaneous flow, total flow, flow velocity	
Function	High and low alarm, exciting alarm, empty pipe alarm, self-diagnosis	
Totalizer	Three built-in totalizers: forward flow, reverse flow and net flow	
Display Unit	L/s, L/m, L/h, m³/s, m³/m, m³/h, UKG, USG, gal/s, gal/m, gal/h, kg/s, kg/m, kg/h, t/s, t/m, t/h	
Language	English, Chinese, Italian, Portuguese, French, Spanish, Korean	



Transmitter Drawing

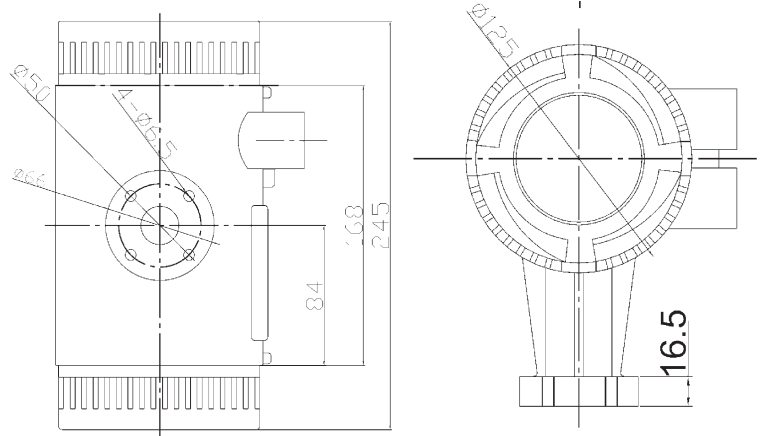

Compact Transmitter

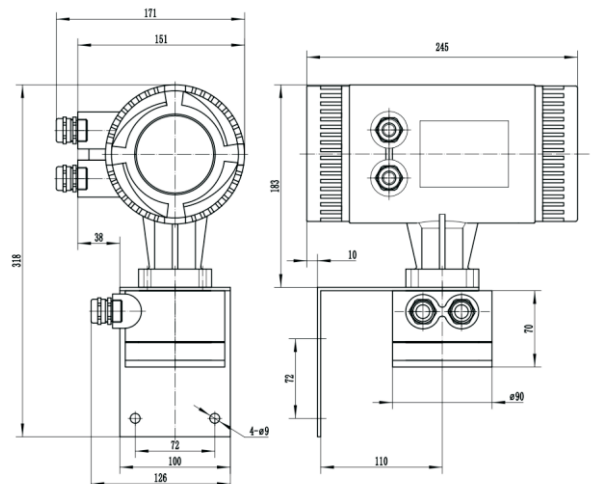
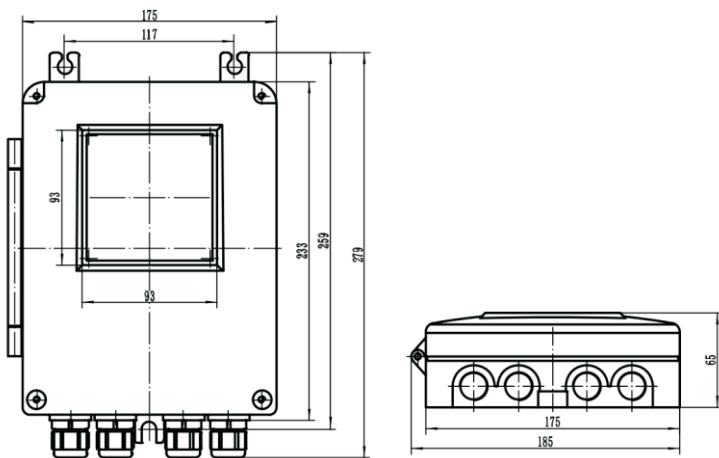

Remote Transmitter

ART Flange Electromagnetic Flow Meter



Dimension

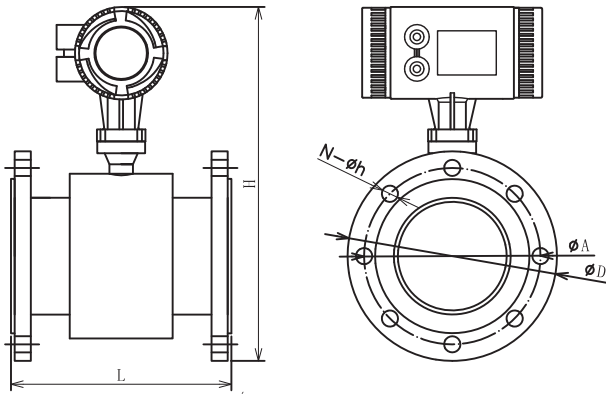

DN15-DN600 Compact Electromagnetic Flow Meter with DIN Drawing

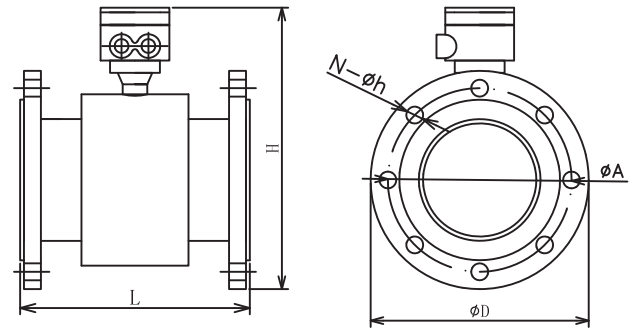

DN15-DN600 Remote Electromagnetic Flow Meter with DIN Drawing

Compact Mag Flow Meter Size

Size	Nominal Pressure	L (mm)	φ D (mm)	φ A (mm)	H (mm)	N-φ h (mm)
15	PN16	200	95	65	332	4-φ 14
20		200	105	75	332	4-φ 14
25		200	115	85	335	4-φ 14
32		200	140	100	352	4-φ 18
40		200	150	110	362	4-φ 18
50		200	165	125	375	4-φ 18
65		200	185	145	395	4-φ 18
80		200	200	160	402	8-φ 18
100		250	220	180	422	8-φ 18
125		250	250	210	452	8-φ 18
150		300	285	240	485	8-φ 22
200		350	340	295	542	12-φ 22
250		450	405	355	607	12-φ 26
300		PN10	500	445	400	652
350	550		505	460	707	16-φ 22
400	600		565	515	770	16-φ 26
450	600		615	565	820	20-φ 26
500	600		670	620	872	20-φ 26
600	600		780	725	994	20-φ 30

Remote Mag Flow Meter Size

Size	Nominal Pressure	L (mm)	φ D (mm)	φ A (mm)	H (mm)	N-φ h (mm)
15	PN16	200	95	65	220	4-φ 14
20		200	105	75	220	4-φ 14
25		200	115	85	223	4-φ 14
32		200	140	100	240	4-φ 18
40		200	150	110	250	4-φ 18
50		200	165	125	263	4-φ 18
65		200	185	145	283	4-φ 18
80		200	200	160	290	8-φ 18
100		250	220	180	310	8-φ 18
125		250	250	210	340	8-φ 18
150		300	285	240	373	8-φ 22
200		350	340	295	430	12-φ 22
250		450	405	355	495	12-φ 26
300		PN10	500	445	400	540
350	550		505	460	595	16-φ 22
400	600		565	515	658	16-φ 26
450	600		615	565	708	20-φ 26
500	600		670	620	760	20-φ 26
600	600		780	725	882	20-φ 30

ART Flange Electromagnetic Flow Meter



Dimension

Size is from 1/2"-24", other sizes can be provided upon request.

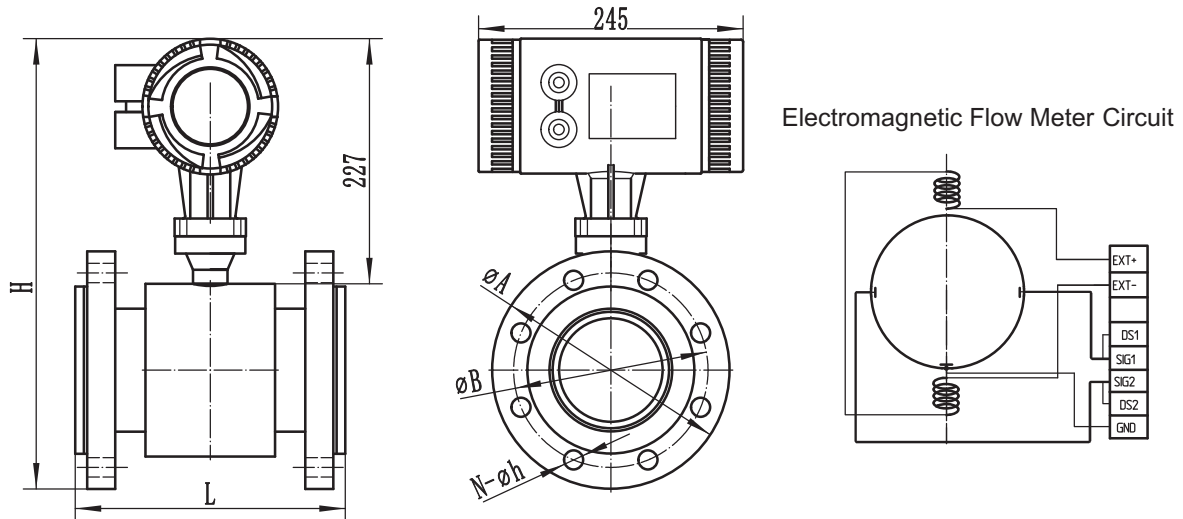

1/2"-24" Compact Electromagnetic Flow Meter with ANSI 150# Drawing

Size	Flange Standard	Pressure Rate	H (mm)	L (mm)	φA (mm)	φB (mm)	N (mm)	φh (mm)
1/2"	ANSI	150#	318	200	88.9	60.45	4	15.7
3/4"	ANSI	150#	323	200	98.6	69.85	4	15.7
1"	ANSI	150#	328	200	108	79.25	4	15.7
1¼"	ANSI	150#	333	200	117.3	88.9	4	15.7
1½"	ANSI	150#	343	200	127	98.6	4	15.7
2"	ANSI	150#	363	200	152.4	120.7	4	19.1
2½"	ANSI	150#	383	200	177.8	139.7	4	19.1
3"	ANSI	150#	398	200	190.5	152.4	4	19.1
4"	ANSI	150#	426	250	228.6	190.5	8	19.1
5"	ANSI	150#	449	250	254	215.9	8	22.4
6"	ANSI	150#	477	300	279.4	241.3	8	22.4
8"	ANSI	150#	538	350	342.9	298.5	8	22.4
10"	ANSI	150#	613	450	406.4	362	12	25.4
12"	ANSI	150#	678	500	482.6	431.8	12	25.4
14"	ANSI	150#	728	550	533.4	476.3	12	28.4
16"	ANSI	150#	784	600	596.9	539.8	16	28.4
18"	ANSI	150#	830	600	635	577.9	16	31.75
20"	ANSI	150#	887	600	698.5	635	20	31.75
24"	ANSI	150#	999	600	812.8	749.3	20	35.1

ART Flange Electromagnetic Flow Meter



Dimension

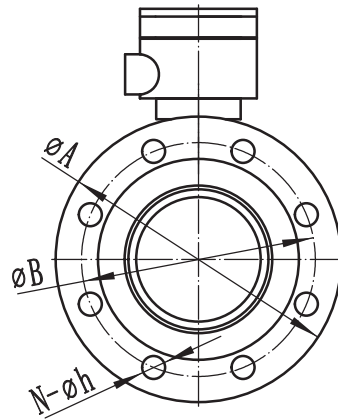
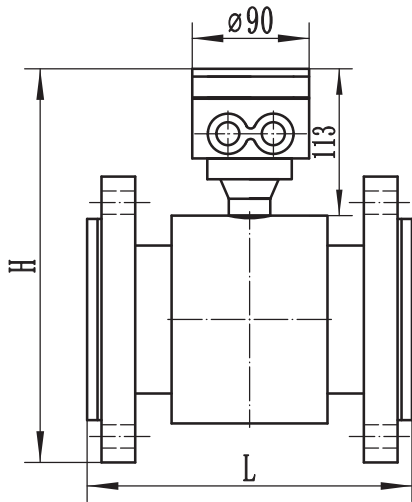

Electromagnetic Flowmeter Circuit

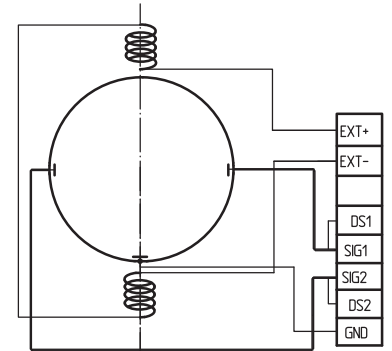

1/2"-24" Remote Electromagnetic Flow Meter with ANSI 150# Drawing

Size	Flange Standard	Pressure Rate	H (mm)	L (mm)	φA (mm)	φB (mm)	N (mm)	φh (mm)
1/2"	ANSI	150#	204	200	88.9	60.45	4	15.7
3/4"	ANSI	150#	209	200	98.6	69.85	4	15.7
1"	ANSI	150#	214	200	108	79.25	4	15.7
1¼"	ANSI	150#	219	200	117.3	88.9	4	15.7
1½"	ANSI	150#	229	200	127	98.6	4	15.7
2"	ANSI	150#	249	200	152.4	120.7	4	19.1
2½"	ANSI	150#	269	200	177.8	139.7	4	19.1
3"	ANSI	150#	284	200	190.5	152.4	4	19.1
4"	ANSI	150#	312	250	228.6	190.5	8	19.1
5"	ANSI	150#	335	250	254	215.9	8	22.4
6"	ANSI	150#	363	300	279.4	241.3	8	22.4
8"	ANSI	150#	424	350	342.9	298.5	8	22.4
10"	ANSI	150#	499	450	406.4	362	12	25.4
12"	ANSI	150#	562	500	482.6	431.8	12	25.4
14"	ANSI	150#	614	550	533.4	476.3	12	28.4
16"	ANSI	150#	670	600	596.9	539.8	16	28.4
18"	ANSI	150#	716	600	635	577.9	16	31.75
20"	ANSI	150#	773	600	698.5	635	20	31.75
24"	ANSI	150#	885	600	812.8	749.3	20	35.1



Main Performance of Electrode Material

Electrode Material	Application
SS316L	Applicable to industrial and municipal water, wastewater and low corrosive mediums. Widely used in petroleum, chemical industries.
Hastelloy B	Strong resistance to hydrochloric acids below the boiling point. Resist against oxidable acids, alkali and non-oxidable salts, like vitriol, phosphate, hydrofluoric acids and organic acids.
Hastelloy C	Exceptional resistance to strong solutions of oxidizing salts and acids, like Fe ⁺⁺⁺ , Cu ⁺⁺ , Nitric acids, mixed acids.
Titanium	Titanium can withstand corrosive mediums such as seawater, chloride salt solutions, hypochlorite salts, oxidable acids (including fuming nitric acids), organic acids, and alkali. Not resistant to high purity reducing acids such as sulphuric acids, hydrochloric acids.
Tantalum	Highly resistant to corrosive mediums. Applicable to all chemical mediums except Hydrofluoric Acids, Oleum and Alkali.
Platinum-iridium	Applicable to all chemical mediums except for Ammonium salts and Fortis.



Main Performance of Liner Material

PTFE	Best chemical resistance, withstand boiling hydrochloric acid, sulfuric acid, nitric acid, alkali and a variety of organic solvents. Poor wear resistance and poor adhesion.
PFA	Highly resistant to chemicals. Performance well under vacuum pressure condition.
Neoprene	Excellent elasticity, good abrasion resistance. Withstand the corrosion of low-concentration acid, alkali, salt and other media. Not resistant to corrosion by oxidizing medium.
Polyurethane	Strong abrasion resistant, applicable for slurries and muds. Poor corrosion resistance, can't be used for corrosive medium.
Hard Rubber	Withstand the corrosion of hydrochloric acid, acetic acid, oxalic acid, ammonia water, phosphoric acid and 50% sulfuric acid, sodium hydroxide, potassium hydroxide. Use for general acid, alkali, and salt solutions, not resistant to the corrosion of strong oxidants.
Ceramic	Withstands high temperature, corrosion and wear Smooth inner Totally vacuum resistant



Flow Range Table

Size		Flow Range & Velocity Table							
mm	Inch	0.1 m/s	0.2 m/s	0.5 m/s	1 m/s	4 m/s	10 m/s	12 m/s	15 m/s
DN3	1/8"	0.003	0.005	0.013	0.025	0.102	0.254	0.305	0.382
DN6	1/4"	0.01	0.02	0.051	0.102	0.407	1.017	1.221	1.526
DN10	3/8"	0.028	0.057	0.141	0.283	1.13	2.826	3.391	4.239
DN15	1/2"	0.064	0.127	0.318	0.636	2.543	6.359	7.63	9.538
DN20	3/4"	0.113	0.226	0.565	1.13	4.522	11.304	13.56	16.956
DN25	1"	0.177	0.353	0.883	1.766	7.065	17.663	21.2	26.494
DN32	1¼"	0.289	0.579	1.447	2.894	11.575	28.938	34.73	43.407
DN40	1½"	0.452	0.904	2.261	4.522	18.086	45.216	54.26	67.824
DN50	2"	0.707	1.413	3.533	7.065	28.26	70.65	84.78	105.98
DN65	2½"	1.19	2.39	5.97	11.94	47.76	119.4	143.3	179.1
DN80	3"	1.81	3.62	9.04	18.09	72.35	180.86	217	271.3
DN100	4"	2.83	5.65	14.13	28.26	113.04	282.6	339.1	423.9
DN125	5"	4.42	8.83	22.08	44.16	176.63	441.56	529.9	662.34
DN150	6"	6.36	12.72	31.79	63.59	254.34	635.85	763	953.78
DN200	8"	11.3	22.61	56.52	113.04	452.16	1130.4	1356	1696
DN250	10"	17.66	35.33	88.31	176.53	706.5	1766.25	2120	2649
DN300	12"	25.43	50.87	127.2	254.34	1017	2543.4	3052	3815
DN350	14"	34.62	69.24	173.1	346.19	1385	3461.85	4154	5193
DN400	16"	45	90	226.1	452	1809	4522	5426	6782
DN450	18"	57	114	286.1	572	2289	5723	6867	8584
DN500	20"	71	141	353.3	707	2826	7065	8478	10598
DN600	24"	102	203	508.7	1017	4069	10174	12208	15260
DN700	28"	138	277	692.4	1385	5539	13847	16617	20771
DN800	32"	181	362	904.3	1809	7235	18086	21704	27130
DN900	36"	229	458	1145	2289	9156	22891	27469	34336
DN1000	40"	283	565	1413	2826	11304	28260	33912	42390
DN1200	48"	407	814	2035	4069	16278	40694	48833	61042
DN1400	56"	554	1108	2769	5539	22156	55390	66468	83084
DN1600	64"	723	1447	3617	7235	28938	72346	86815	108518
DN1800	72"	916	1831	4578	9156	36625	91562	109875	137344
DN2000	80"	1130	2261	5652	11304	45216	113040	135648	169560
DN2200	88"	1368	2736	6839	13678	54711	136778	164134	205168
DN2400	96"	1628	3256	8139	16278	65111	162778	195333	244166
DN2600	104"	1910	3821	9552	19104	76415	191038	229245	286556
DN2800	112"	2216	4431	11078	22156	88623	221558	265870	332338
DN3000	120"	2543	5087	12717	25434	101736	254340	305208	381510

Remark: Recommend flow velocity range 0.5 ~ 15 m/s

ART Tri-clamp Electromagnetic Flow Meter



Description

ART tri-clamp magnetic flow meter is designed for sanitary applications, size is DN15-DN200, the sensor is SS304 or SS316 and lined with PFA. With tri-clamp, the magnetic flow meter can be installed and torn down easily to clear, it meet the strict requirements of food-processing and pharmaceutical industries.



Industries



Food Processing CIP/SIP



Industries Process or Industry



Filling and metering of infusion products such as saline and glucose water.



Filling and metering of liquid foods such as vegetable juice, juice, beer.



Pharmaceutical Industry



Food and Beverage Industry



Features

- Tri-clamp electromagnetic flow meter is easy to be installed and dismantled.
- It adopts harmless food grade stainless steel as raw material, so it can contact with food directly.
- It is easy to clean, customer just need open the tri-clamp and dismantle the flow meter.
- It has current output and pulse output for connecting with PLC or other devices. And user can also read flow measurement by RS485/HART/Profibus.
- Stainless steel material has long service life, and it can be used to measure most of drinks.



Technical Data

Size	DN15-DN200 (1/2"-8")	
Accuracy	$\pm 0.5\%$ of reading at flow rate $\geq 0.5\text{m/s}$, $\pm 0.2\%$ optional at flow velocity $\geq 0.5\text{m/s}$	
Velocity	0.1~15 m/s	
Repeatability	$\leq 0.17\%$	
Structure	Compact / remote, cable length 10m standard, 100m max	
Conductivity	$> 5 \mu\text{S/cm}$, demineralized water $> 20 \mu\text{S/cm}$	
Protection Grade	Transmitter: IP65 standard, IP67 optional	
	Sensor: IP65 std, IP68 (submersible, only available for remote type)	
Electrode	SS316L	
Power Supply	85~250 VAC (50/60 HZ), 20~36 VDC	
Power Consumption	$< 20\text{W}$	
Signal Output	Analog	4~20mA (load resistor 0~750 Ω)
	Frequency	Forward & reverse flow output with a frequency range of 1~5000Hz
	Alarm	Two isolated open collector transistor (OCT) outputs for alarm signals
Communication	RS485 MODBUS standard, HART, GPRS, PROFIBUS optional	
Display	LCD Display, 128X128mm, three lines, 4 buttons	
Ambient Temperature	$-20^{\circ}\text{C} \sim 60^{\circ}\text{C}$	
Fluid Temperature	Compact: $-20^{\circ}\text{C} \sim 80^{\circ}\text{C}$, Remote: $-20^{\circ}\text{C} \sim 120^{\circ}\text{C}$	
Liner material	PFA	
Sensor Material	Measuring tube: SS304	
	Tri-clamp & housing: SS304 standard, SS316 optional	
Transmitter Material	Aluminium alloy with epoxy painting	
Nominal Pressure	1.6 Mpa	
Display	Instantaneous flow, total flow, flow velocity	
Function	High and low alarm, empty pipe alarm, exciting alarm, self-diagnosis	
Totalizer	Three built-in totalizers: forward flow, reverse flow and net flow	
Display Unit	L/s, L/m, L/h, m ³ /s, m ³ /m, m ³ /h, UKG, USG, gal/s, gal/m, gal/h, kg/s, kg/m, kg/h, t/s, t/m, t/h	
Language	English, Chinese, Italian, Portuguese, French, Spanish, Korean	

ART Tri-clamp Electromagnetic Flow Meter



Dimension

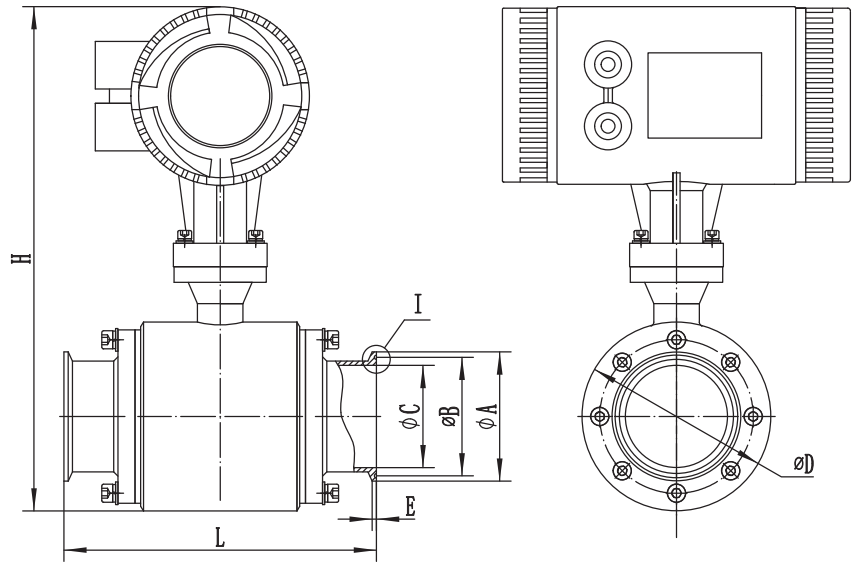

DN15-DN200 (1/2"-8") Sanitary (Tri-clamp) Electromagnetic Flow Meter Drawing (Compact)

Size		φA(mm)	φB(mm)	φC(mm)	φD(mm)	E(mm)	H(mm)	L(mm)
mm	Inch							
DN15	1/2"	50.5	43.5	16	76	2.85	303	200
DN20	3/4"	50.5	43.5	19	83	2.85	310	200
DN25	1"	50.5	43.5	24	83	2.85	310	200
DN32	1¼"	50.5	43.5	31	94	2.85	321	200
DN40	1½"	50.5	43.5	35	94	2.85	321	200
DN50	2"	64	56.5	45	108	2.85	335	200
DN65	2½"	77.5	70.5	59	115	2.85	342	250
DN80	3"	91	83.5	72	135	2.85	362	250
DN100	4"	119	110	98	159	2.85	386	250
DN125	5"	145	136	129	183	3.6	410	300
DN150	6"	183	174	150	219	3.6	446	300
DN200	8"	233.5	225	199	261	3.6	488	350

ART Tri-clamp Electromagnetic Flow Meter



Dimension

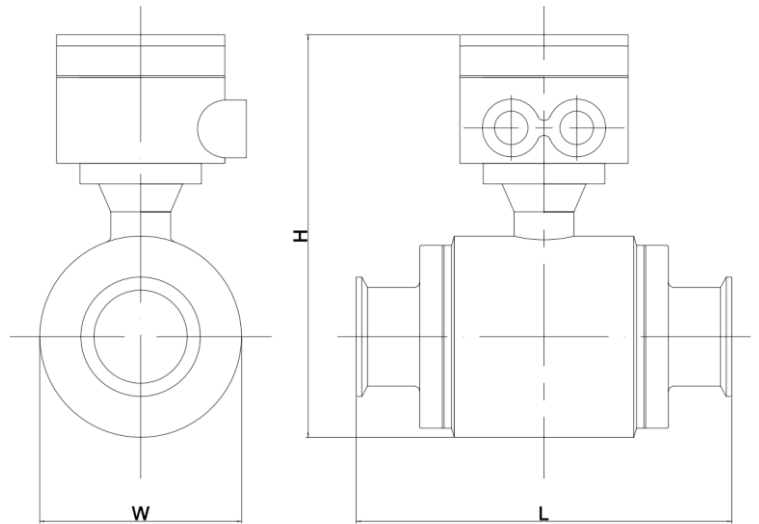

DN15-DN200 (1/2"-8") Sanitary (Tri-clamp) Electromagnetic Flow Meter Drawing (Remote)

Size		H(mm)	L(mm)	W(mm)
mm	Inch			
DN15	1/2"	188	200	76
DN20	3/4"	191	200	83
DN25	1"	191	200	83
DN32	1¼"	202	200	94
DN40	1½"	202	200	94
DN50	2"	216	200	108
DN65	2½"	223	250	115
DN80	3"	243	250	135
DN100	4"	267	250	159
DN150	6"	327	300	219
DN200	8"	369	350	273



Description

ART wafer electromagnetic flow meter is designed with flangeless structure for minimum size and weight. Eliminate gaskets and prevent moisture ingress with an all-welded sensor. No moving parts, which reduced the maintenance and repair with an obstructionless design. Alignment rings are available to install easily.



Features

- Wafer electromagnetic flow meter has short body, it can be installed in narrow areas such as well, ditch, irrigation pipe, etc.
- And wafer electromagnetic flow meter adopts harmless and durable stainless steel as raw material(SS304 or SS316), so it can be used for drinking water, underground water, etc. For food grade measurement, we suggest customer use SS316 material.
- Wafer electromagnetic flow meter is easy to deliver, save your freight fee. Not only its body is short and thin, but its weight is also very light.
- It has multiple output signals for selection. It has current output and pulse output for connecting with PLC or other devices. And you can also read flow measurement by RS485/HART/Profibus.





Technical Data

Size	DN25-DN200 /1"-8"	
Accuracy	$\pm 0.5\%$ of reading at flow rate $\geq 0.5\text{m/s}$, $\pm 0.2\%$ optional at flow velocity $\geq 0.5\text{m/s}$	
Velocity	0.1~15 m/s	
Repeatability	$\leq 0.17\%$	
Structure	Compact / remote, cable length 10m standard, 100m max	
Conductivity	$> 5 \mu\text{S/cm}$, demineralized water $> 20 \mu\text{S/cm}$	
Protection Grade	Transmitter: IP65 standard, IP67 optional	
	Sensor: IP65 standard, IP68 (submersible, only available for remote type)	
Electrode	SS316L, Hastelloy C, Hastelloy B, Titanium, Tantalum, Platinum-iridium	
Power Supply	85~250 VAC (50/60 Hz), 20~36 VDC	
Power Consumption	$< 20\text{W}$	
Signal Output	Analog	4~20mA (load resistor 0~750 Ω)
	Frequency	Forward & reverse flow output with a frequency range of 1~5000Hz
	Alarm	Two isolated open collector transistor (OCT) outputs for alarm signals
Communication	RS485 MODBUS std, HART, GPRS, PROFIBUS optional	
Display	LCD Display, 128X128mm, three lines, 4 buttons	
Ambient Temperature	$-20^{\circ}\text{C} \sim 60^{\circ}\text{C}$	
Fluid Temperature	Compact: $-20^{\circ}\text{C} \sim 80^{\circ}\text{C}$, Remote: $-20^{\circ}\text{C} \sim 120^{\circ}\text{C}$	
Liner Material	PTFE FEP PFA	
Sensor Material	Carbon steel (standard), SS304 / SS316 optional	
Transmitter Material	Aluminium alloy with epoxy painting	
Nominal Pressure	1.6 Mpa	
Display	Instantaneous flow, total flow, flow velocity	
Function	High and low alarm, empty pipe alarm, exciting alarm, self-diagnosis	
Totalizer	Three built-in totalizers: forward flow, reverse flow and net flow	
Display Unit	L/s, L/m, L/h, m^3/s , m^3/m , m^3/h , UKG, USG, gal/s, gal/m, gal/h, kg/s, kg/m, kg/h, t/s, t/m, t/h	
Language	English, Chinese, Italian, Portuguese, French, Spanish, Korean	

ART Wafer Electromagnetic Flow Meter



Dimension

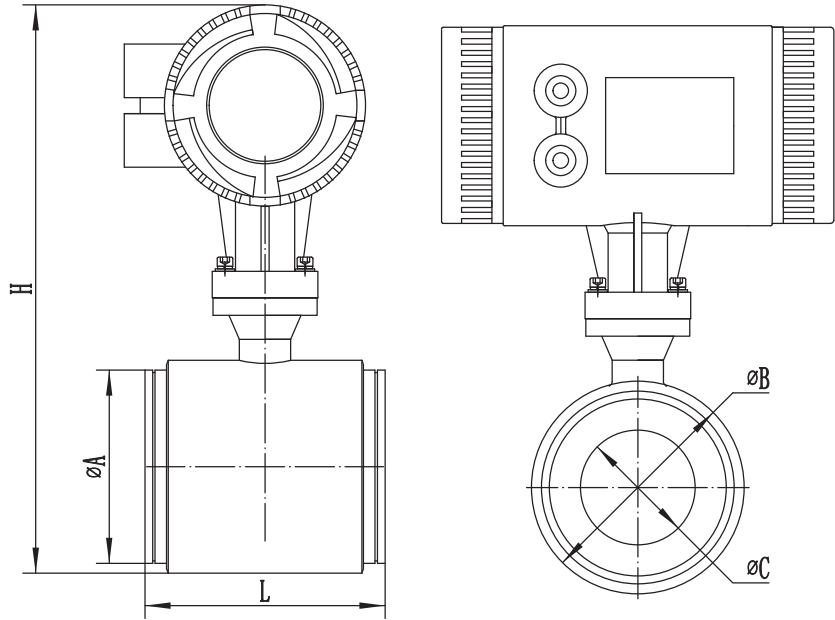

DN25-DN200 (1"-8") Wafer Electromagnetic Flow Meter Drawing (Compact)

Size		$\phi A(\text{mm})$	$\phi B(\text{mm})$	$\phi C(\text{mm})$	$H(\text{mm})$	$L(\text{mm})$
mm	Inch					
DN25	1"	60.5	68	22	295	100
DN32	1¼"	68.5	76	30	303	100
DN40	1½"	74.5	89	36	316	100
DN50	2"	90.8	102	48	329	100
DN65	2½"	109.8	119.5	64	346.5	150
DN80	3"	120.7	133	77	360	150
DN100	4"	150.2	159	102	386	150
DN125	5"	174.8	190	121	417	200
DN150	6"	204.7	219	147	446	200
DN200	8"	257.8	237	207	500	200

ART Wafer Electromagnetic Flow Meter



Dimension

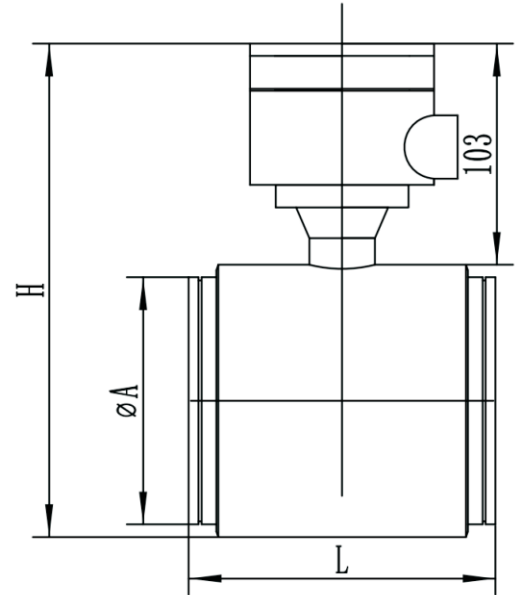

Size		φA(mm)	φB(mm)	L(mm)	H(mm)
Size	Inch				
DN25	1"	60	68	98	181
DN32	1¼"	68	76	98	189
DN40	1½"	74	89	98	202
DN50	2"	90	102	98	215
DN65	2½"	110	120	146	233
DN80	3"	120	132	146	245
DN100	4"	150	159	146	272
DN150	6"	204	219	196	332

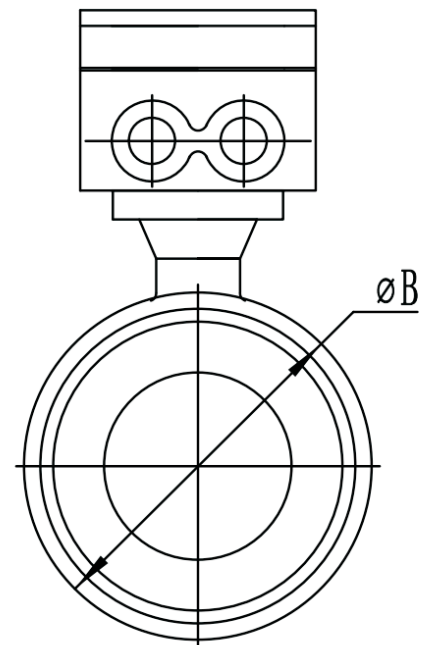

DN25-DN150 (1"-6") Wafer Electromagnetic Flow Meter Drawing (Remote)

ARTC Insertion Electromagnetic Flow Meter

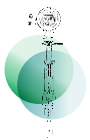

Description

ART insertion electromagnetic flow meter is used to measure the flow of conductive liquids. It is available for use in pipes ranging in size from DN100 to DN3000. It can configure thread or flange ball valve to be hot-tapped, which allows sensor to be installed and retracted from process piping without shutting down the process.

It's an economic alternative when installed in large pipeline no matter in cost and delivery compared with full bore magnetic flow meter.



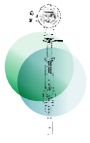

Industries

Effluent Treatment Plant	Sewage Treatment Plant Water Supply Scheme	Steel & Aluminum Industries	Food & Drug Industries
Chemical & Fertilizer Industries	Dairy Industries	Sugar Industries	Textile Processing Industries

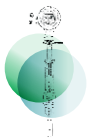

Applications

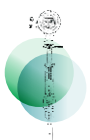

Features

- No moving parts, no pressure loss and require very less maintenance.
- More economical option for large pipelines flow measurement.
- It can achieve hot-tapping online installation.
- Simple structure, light weight and easy to transport.
- Bi-directional flow measurement.
- Automatic self-diagnosis.
- Protection Class: IP68 (sensor submersible) available.

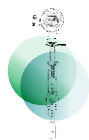

Technical Data

Size	DN100-DN3000 (4"-120")	
Accuracy	±1.5% of reading at flow velocity ≥ 0.5 m/s	
Velocity	0.1~15 m/s	
Repeatability	≤0.17%	
Structure	Compact / remote, cable length 10m standard, 100m max	
Conductivity	> 5 μ S/cm, demineralized water > 20 μ S/cm	
Protection Grade	Transmitter: IP65 standard, IP67 optional	
	Sensor: IP65 standard, IP68 (submersible, only available for remote type)	
Electrode	SS316L, Hastelloy C, Hastelloy B, Titanium, Tantalum, Platinoidium	
Power Supply	85~250 VAC (50/60 Hz), 8~36 VDC	
Power Consumption	<20W	
Signal Output	Analog	4~20mA (load resistor 0~750 Ω)
	Frequency	Forward & reverse flow output with a frequency range of 1~5000Hz
	Alarm	Two isolated open collector transistor (OCT) outputs for alarm signals
Communication	RS485 MODBUS standard, HART, GPRS, PROFIBUS optional	
Display	LCD Display, 128X128mm, three lines, 4 buttons	
Ambient Temperature	-20°C~60°C	
Fluid Temperature	-20°C~80°C	
Process connection	G2" thread ball valve	
	DN50 flange ball valve	
Sensor material	Probe material: ABS standard, Polypropylene optional	
	Valve: SS316	
	Pole: SS304	
Transmitter Material	Aluminium alloy with epoxy painting	
Nominal Pressure	1.6 Mpa	
Display	Instantaneous flow, total flow, flow velocity	
Function	High and low alarm, empty pipe alarm, exciting alarm, self-diagnosis	
Totalizer	Three built-in totalizers: forward flow, reverse flow and net flow	
Display Unit	L/s, L/m, L/h, m ³ /s, m ³ /m, m ³ /h, UKG, USG, gal/s, gal/m, gal/h, kg/s, kg/m, kg/h, t/s, t/m, t/h	
Language	English, Chinese, Italian, Portuguese, French, Spanish, Korean	

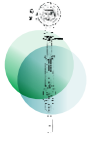

Type



Compact Insertion Magnetic Flow Meter with Thread Ball Valve



Remote Insertion Magnetic Flow Meter with Thread Ball Valve



Compact Insertion Magnetic Flow Meter with Flange Ball Valve



Remote Insertion Magnetic Flow Meter with Flange Ball Valve

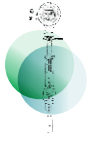

Dimension

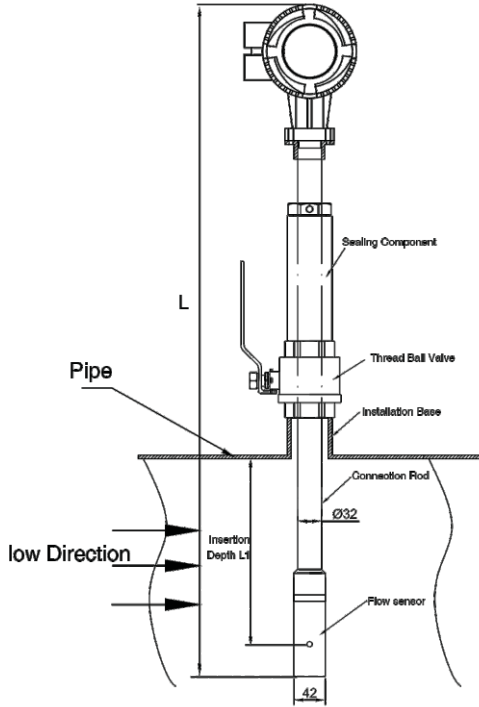

Specifications		
Pipe Size	Length(L)	Insertion Length L1
DN ≤ 200	693mm	$\frac{1}{2}$ DN
400 ≥ DN ≥ 250	793mm	
1200 ≥ DN > 400	893mm	$\frac{1}{4}$ DN
2000 ≥ DN > 1400	1093mm	

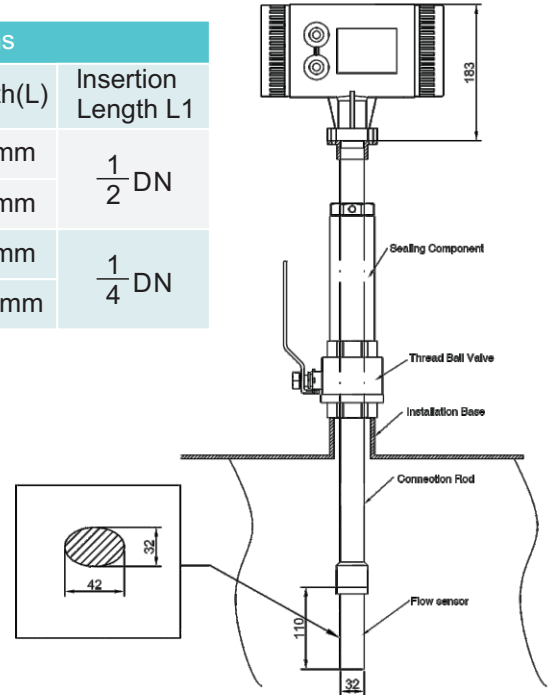

4"-80" Thread Ball Valve Insertion Electromagnetic Flow Meter Drawing (Compact)

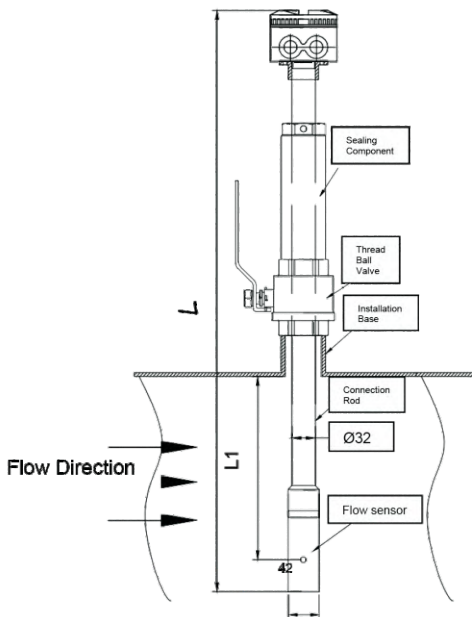

Specifications		
Pipe Size	Length(L)	Insertion Length L1
DN ≤ 200	583mm	$\frac{1}{2}$ DN
400 ≥ DN ≥ 250	683mm	
1200 ≥ DN > 400	783mm	$\frac{1}{4}$ DN
2000 ≥ DN > 1400	983mm	

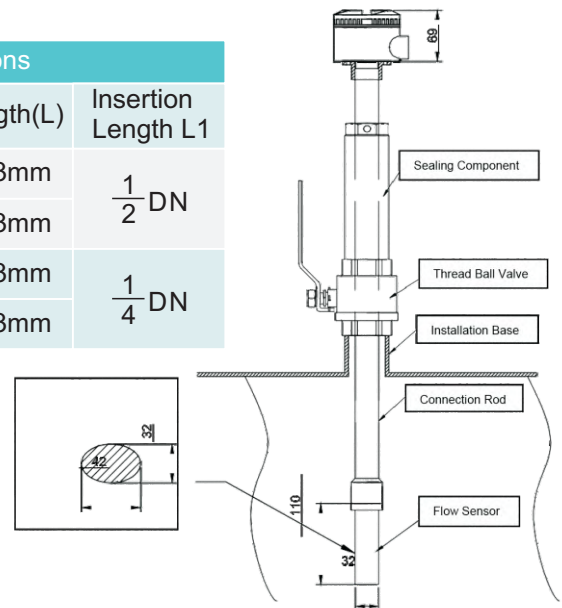

4"-80" Thread Ball Valve Insertion Electromagnetic Flow Meter Drawing (Remote)



Dimension

Specifications		
Pipe Size	Length(L)	Insertion Length L1
DN ≤ 200	480mm	$\frac{1}{2}$ DN
400 ≥ DN ≥ 250	580mm	$\frac{1}{2}$ DN
1200 ≥ DN > 400	680mm	$\frac{1}{4}$ DN
2000 ≥ DN > 1400	880mm	$\frac{1}{4}$ DN

4"-80" Flange Ball Valve Insertion Electromagnetic Flow Meter Drawing (Compact)

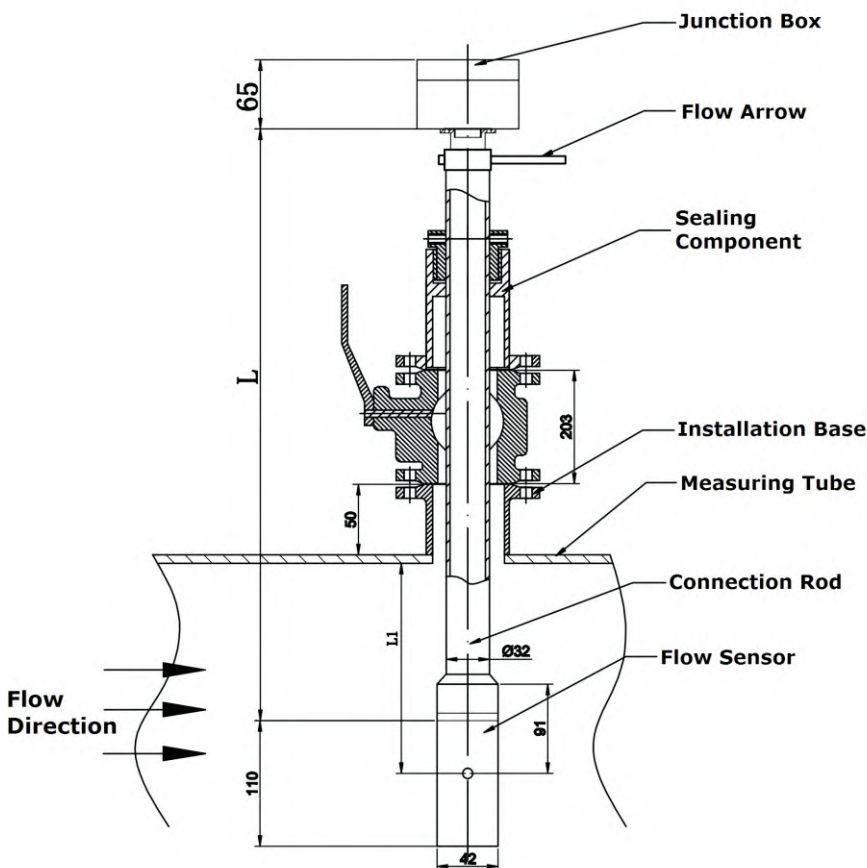
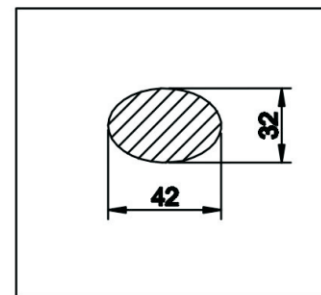
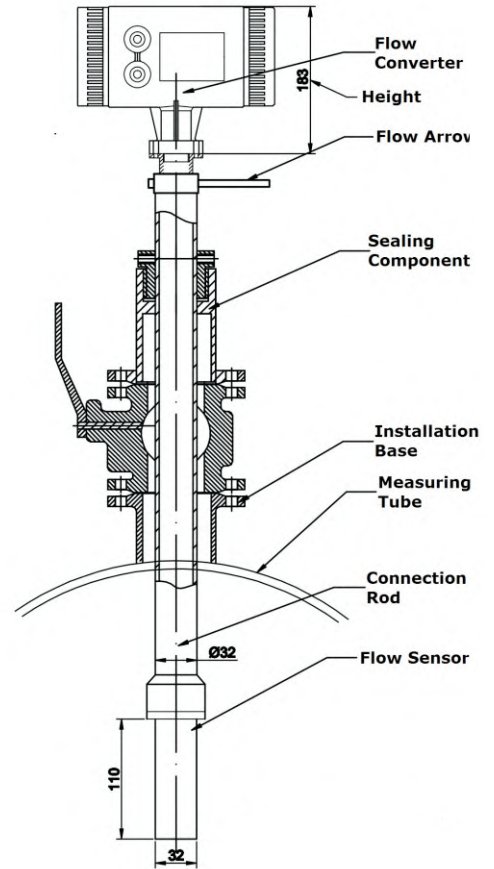

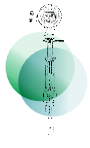

Insertion Electromagnetic Flow Meter

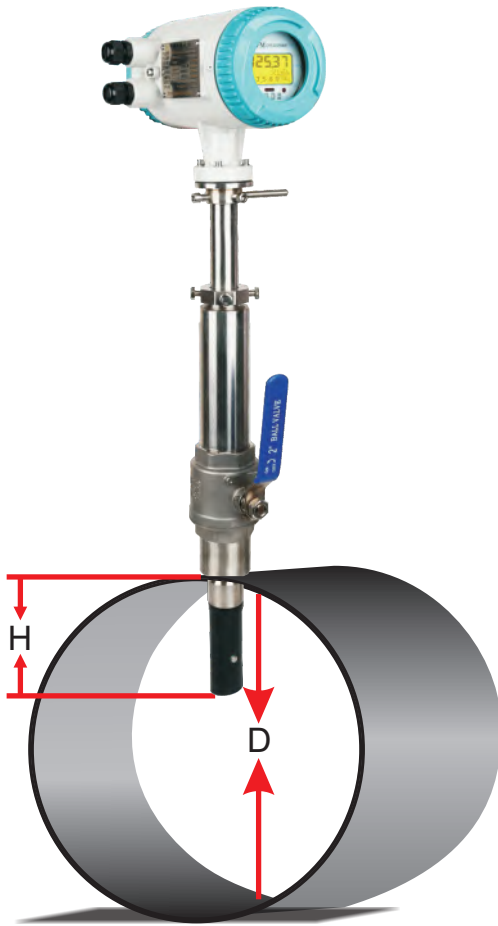

$D \leq 400\text{mm}, H = 1/2 D$
 $D > 400\text{mm}, H = 1/4 D$

Remarks:

Insertion depth has no relationship with pipe thickness. For example, DN400 pipe thickness is 5mm, insertion depth should be $1/2$ of 400mm, the L1 should be 200 mm.

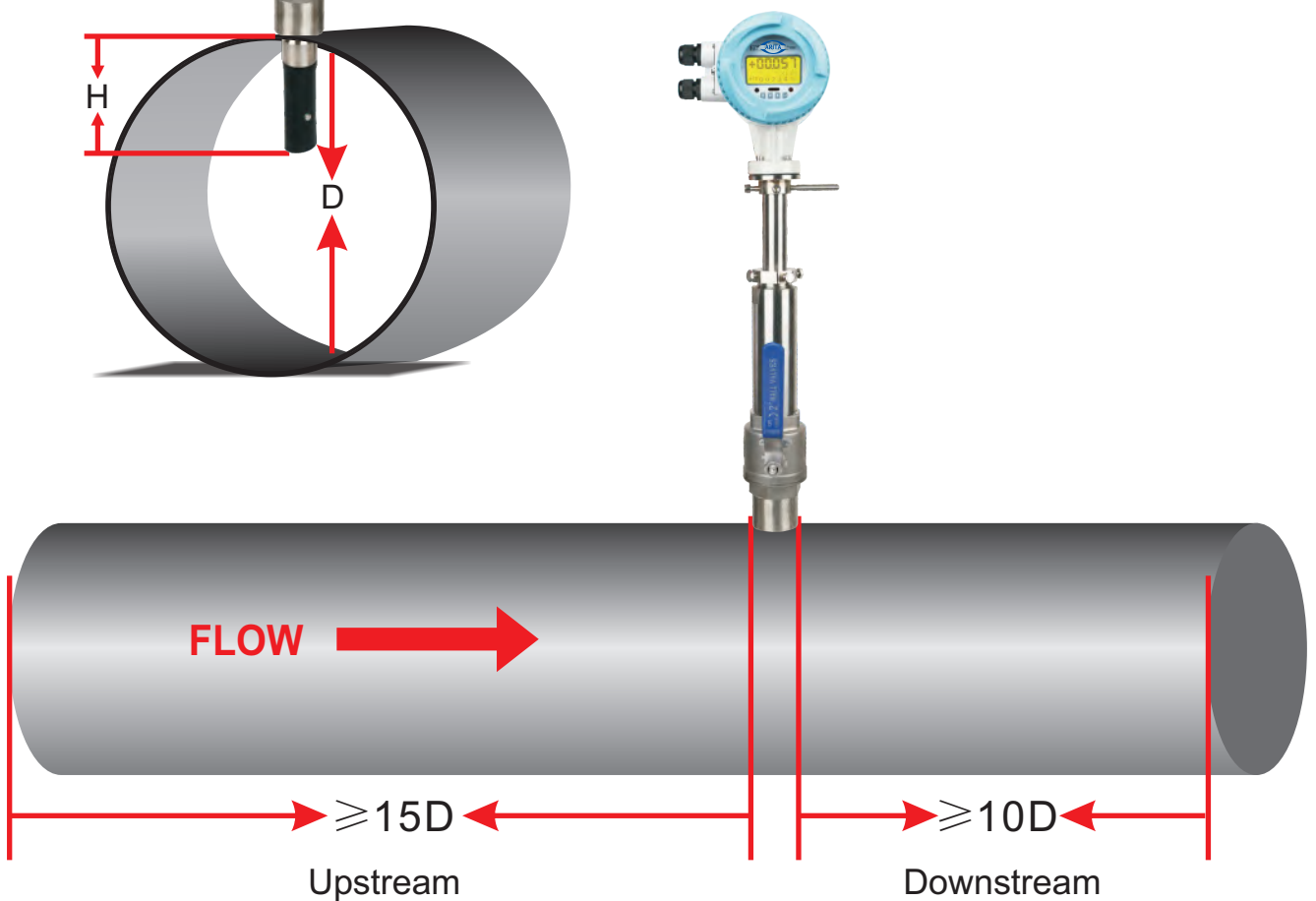

ART Battery-powered Electromagnetic Flow Meter



Description

ART battery-powered electromagnetic flow meter is an ideal flow measurement device for water and wastewater systems located at remote sites. Various signal and communication are available like, pulse, RS485, all real-time flow data can be monitored on computer or mobile phone by GPRS. Beside flow, it also can measure temperature or pressure. With 5 pcs of 3.6V lithium battery, lifespan is up to 8 years, and battery can be changed when it's used up. The transmitter shell is SS304 and the protection grade is IP68, which is available to be buried or submerged in the water.



Industries

- | | |
|--|------------------------------------|
| ● Effluent Treatment Plant | ● Chemical & Fertilizer Industries |
| ● Sewage Treatment Plant Water Supply Scheme | ● Dairy Industries |
| ● Steel & Aluminum Industries | ● Sugar Industries |
| ● Food & Drug Industries | ● Textile Processing Industries |



Applications



Features

- 01 It has a long life span, standard battery can work for 3-8 years, determined by the excitation current.
- 02 Dual power supply: it's equipped with external power supply interface, which can be powered by external 12-24VDC power supply, enabling users to have a variety of power options.
- 03 Multiple work mode: ART has 'Flow Only' mode, 'Flow + Pressure' mode, 'Flow + Temperature' mode for users.
- 04 Multiple network interfaces: ART has GPRS, RS485, HART and other network communication for users.
- 05 3.6V lithium battery can be changed if its used up.
- 06 Infrared remote control display and operation.



Technical Data

Size	DN10-DN2000 (3/8"~80")
Accuracy	±0.5% of reading at flow velocity ≥ 0.5m/s, ±0.2% optional at flow velocity ≥ 0.5m/s
Velocity	0.1~15 m/s
Repeatability	≤ 0.17%
Structure	Compact / remote, cable length 10m standard, 100m max

ART Battery-powered Electromagnetic Flow Meter

Conductivity	> 5 $\mu\text{S/cm}$, demineralized water > 20 $\mu\text{S/cm}$	
Protection Grade	Transmitter: IP65 standard, IP68 optional	
	Sensor: IP65 standard, IP68 (submersible, only available for remote type)	
Electrode	SS316L, Hastelloy C, Hastelloy B, Titanium, Tantalum, Platinum-iridium	
Power Supply	3.6V lithium Battery	
Power Consumption	<20W	
Signal Output	4 ~ 20 mA, Pulse	
Communication	RS485 MODBUS standard, HART, GPRS, PROFIBUS optional	
Display	LCD Display, 128X128mm, three lines, 4 buttons	
Ambient Temperature	-20°C~60°C	
Fluid Temperature	Compact: -20°C~80°C, Remote: -20°C~120°C	
Liner Material	PTFE (-20°C~150°C, DN15-DN1600)	
	FEP (-20°C~120°C, DN3-DN1800)	
	PFA (-20°C~160°C, DN3-DN800)	
	Polyurethane (-10°C~60°C, DN40-DN1600)	
	Neoprene (-10°C~80°C, DN40-DN3000)	
	Hard Rubber (-10°C~80°C, DN 40-DN3000)	
	Ceramic (-20°C~180°C, DN15-DN200)	
Process connection	Flange, tri-clamp, wafer, thread, insertion	
Sensor Material	Measuring tube: SS304	
	Flange & housing: carbon steel (standard), SS304 / SS316 optional	
Transmitter Material	SS304	
Nominal Pressure	Flange	PN10 / PN16 / PN25 / PN40 DIN 10K / 20K / 30 K JIS 150# / 300# / 600# ANSI Others
	Insertion, tri-clamp, wafer, thread	PN16
Display	Instantaneous flow, total flow, flow velocity	
Function	High and low alarm, empty pipe alarm, exciting alarm, self-diagnosis	
Totalizer	Three built-in totalizers: forward flow, reverse flow and net flow	
Display Unit	L/s, L/m, L/h, m ³ /s, m ³ /m, m ³ /h, UKG, USG, gal/s, gal/m, gal/h, kg/s, kg/m, kg/h, t/s, t/m, t/h	



Measuring Mode

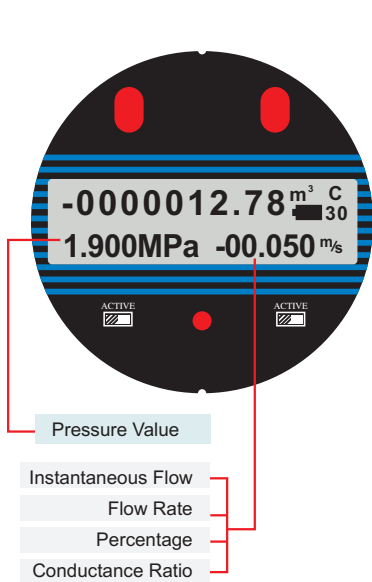
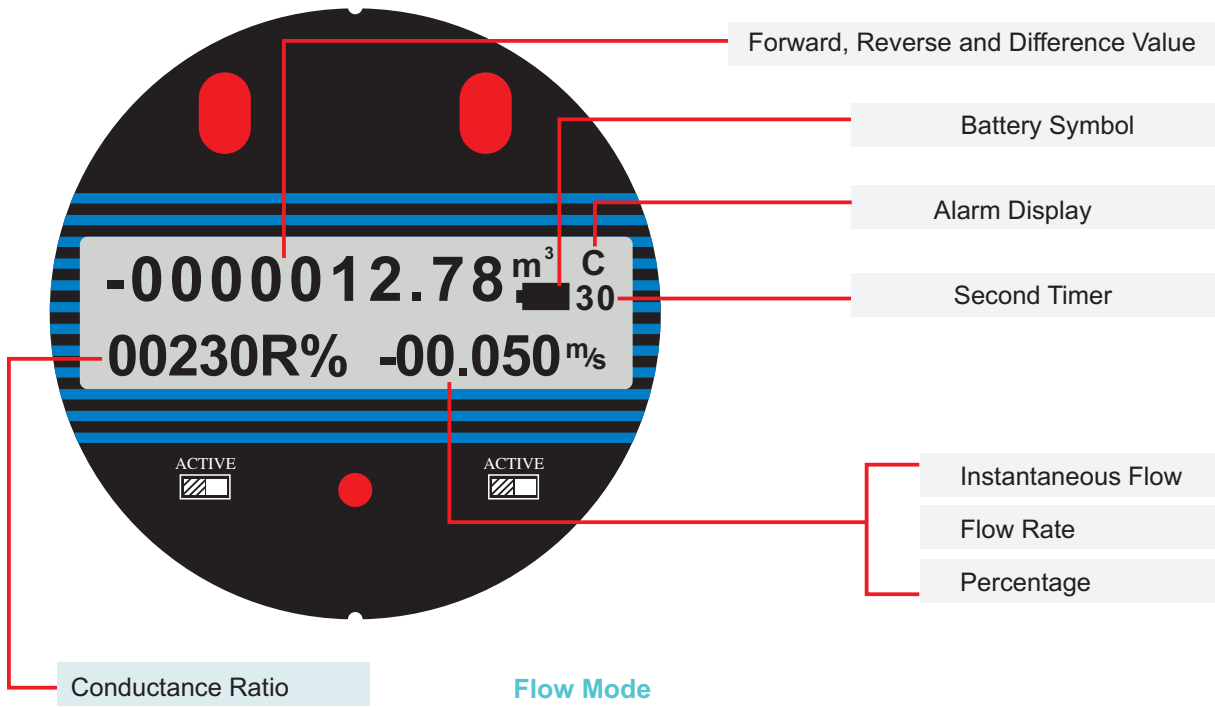

Flow + Pressure Mode

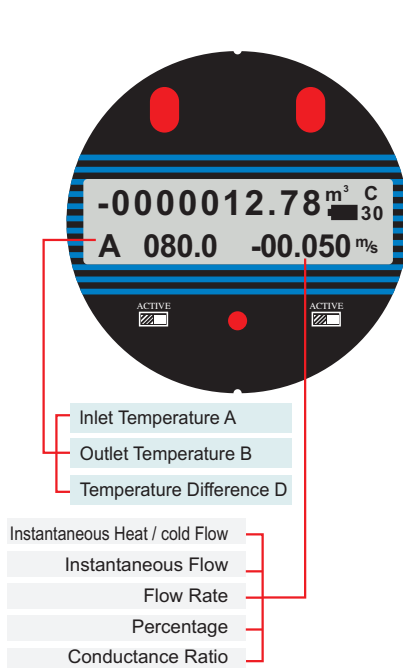

Flow + Temperature Mode

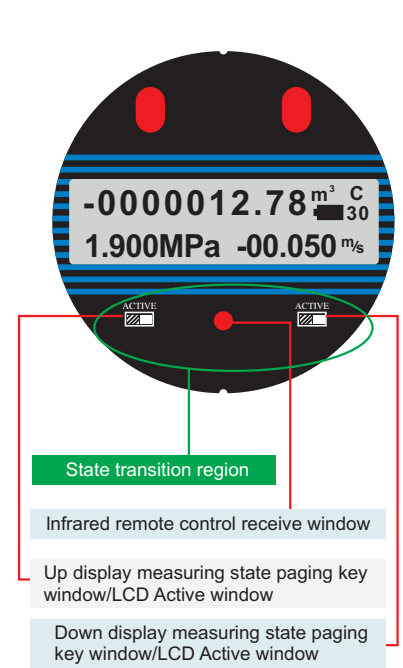

Magnetic Key Operational Position



Dimension

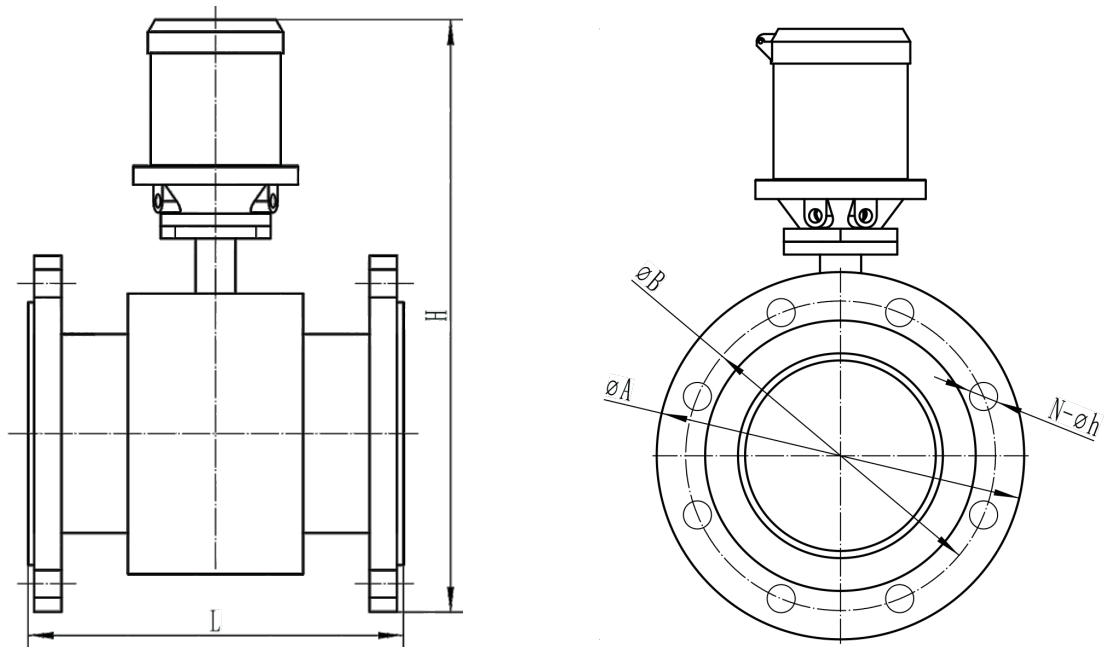

Size		Flange Standard	Nominal Pressure	H (mm)	L (mm)	φA (mm)	φB (mm)	φh (mm)	N (mm)
mm	mm								
DN15	1/2"	DIN	PN16	315	200	95	65	14	4
DN20	3/4"	DIN	PN16	320	200	105	75	14	4
DN25	1"	DIN	PN16	325	200	115	85	14	4
DN32	1¼"	DIN	PN16	337	200	140	100	18	4
DN40	1½"	DIN	PN16	347	200	150	110	18	4
DN50	2"	DIN	PN16	363	200	165	125	18	4
DN65	2½"	DIN	PN16	380	200	185	145	18	4
DN80	3"	DIN	PN16	396	200	200	160	18	8
DN100	4"	DIN	PN16	415	250	220	180	18	8
DN125	5"	DIN	PN16	440	250	250	210	18	8
DN150	6"	DIN	PN16	473	300	285	240	22	8
DN200	8"	DIN	PN16	530	350	340	295	22	12
DN250	10"	DIN	PN16	606	450	405	355	26	12
DN300	12"	DIN	PN16	659	500	460	410	26	12
DN350	14"	DIN	PN16	715	550	520	470	26	16
DN400	16"	DIN	PN16	770	600	580	525	30	16
DN450	18"	DIN	PN16	826	600	640	585	30	20
DN500	20"	DIN	PN16	889	600	715	650	33	20
DN600	24"	DIN	PN16	1007	600	840	770	36	20
DN700	28"	DIN	PN16	1093	700	910	840	36	24
DN800	32"	DIN	PN16	1201	800	1025	950	39	24
DN900	36"	DIN	PN16	1301	900	1125	1050	39	28
DN1000	40"	DIN	PN16	1426	1000	1255	1170	42	28



Communication



Process Connection

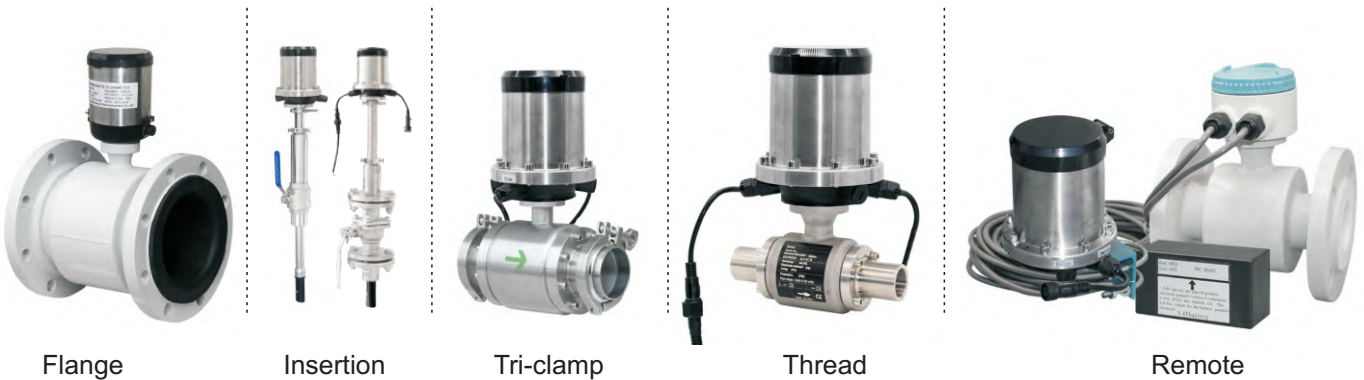



Description

ART partially-filled flowmeter is composed of converter, flow sensor and level sensor. The user only needs to enter the diameter of pipe, the non-full pipe flowmeter will automatically calculate the flow rate, and automatically display the instantaneous flow, total flow, velocity, height, etc. It can measure liquid volume min 10% of full pipe. It is especially suitable for the needs of municipal rainwater, waste water, sewage discharge and irrigation.



Suitable For Low Flow Rate

Can measure liquid volume min 10% of full pipe

Small Blind Zone 60mm



Features

- Partially filled pipe electromagnetic flow meter can measure partially filled pipe liquid flow, it is very popular in irrigation.
- Its can use solar power supply, this type is very suitable for remote areas where has no industrial power supply.
- It adopts safe and durable material, service life is longer than normal products. Normally, it can work at least 5-10 years or longer.
- And we have already got food grade certificate for its liner so it can be used for drinking water, underground water, etc. Many drinking water companies use this type in their big size pipelines.
- We use an accurate mini ultrasonic level meter for its liquid level measurement then the flow meter will record the liquid level and use this parameter to measure liquid flow. This ultrasonic level meter's blind area is very small and its accuracy can reach $\pm 1\text{mm}$.



Technical Data

Size	DN200-DN3000 (8"-120")	
Accuracy	$\pm 2.5\%$ of reading at flow velocity $\geq 0.5\text{m/s}$	
Velocity	0.1~15 m/s	
Structure	Remote, cable length 10m standard, 100m max	
Conductivity	$> 5 \mu\text{S/cm}$, demineralized water $> 20 \mu\text{S/cm}$	
Protection Grade	Transmitter: IP65	
	Sensor: IP65 standard, IP68 (submersible, only available for remote type)	
Electrode	SS316L, Hastelloy C, Hastelloy B, Titanium, Tantalum, Platinum-iridium	
Power Supply	85~250 VAC (50/60 Hz), 20~36 VDC	
Power Consumption	$< 20\text{W}$	
Signal Output	Analog	4~20mA (load resistor 0~750 Ω)
	Frequency	Forward & reverse flow output with a frequency range of 1~5000Hz
	Alarm	Two isolated open collector transistor (OCT) outputs for alarm signals
Communication	Rs485 MODBUS standard, HART, GPRS, PROFIBUS optional	
Display	LCD Display, 128X128mm, three lines, 4 buttons	
Ambient Temperature	$-20^{\circ}\text{C} \sim 60^{\circ}\text{C}$	
Fluid Temperature	$-20^{\circ}\text{C} \sim 120^{\circ}\text{C}$	
Liner Material	PTFE ($-20^{\circ}\text{C} \sim 150^{\circ}\text{C}$, DN200-DN1600)	
	FEP ($-20^{\circ}\text{C} \sim 120^{\circ}\text{C}$, DN200-DN1800)	
	PFA ($-20^{\circ}\text{C} \sim 160^{\circ}\text{C}$, DN200-DN800)	
	Polyurethane ($-10^{\circ}\text{C} \sim 60^{\circ}\text{C}$, DN200-DN1600)	
Flange	DIN PN10 / PN16 / PN25 / PN40 / PN64 / PN100	
	JIS 10K / 20K / 30 K	
	ANSI 150# / 300# / 600#	
Sensor Material	Measuring tube: SS304	
	Flange & housing: carbon steel (standard), SS304 / SS316 optional	
Transmitter Material	Aluminium alloy with epoxy painting	
Nominal Pressure	0.6Mpa, 150lb optional	
Display	Instantaneous flow, total flow, flow velocity	
Function	High and low alarm, empty pipe alarm, exciting alarm, self-diagnosis	
Totalizer	Three built-in totalizers: forward flow, reverse flow and net flow	
Display Unit	L/s, L/m, L/h, m^3/s , m^3/m , m^3/h , UKG, USG, gal/s, gal/m, gal/h, kg/s, kg/m, kg/h, t/s, t/m, t/h	
Language	English	

ART Partially-filled Electromagnetic Flow Meter



Features

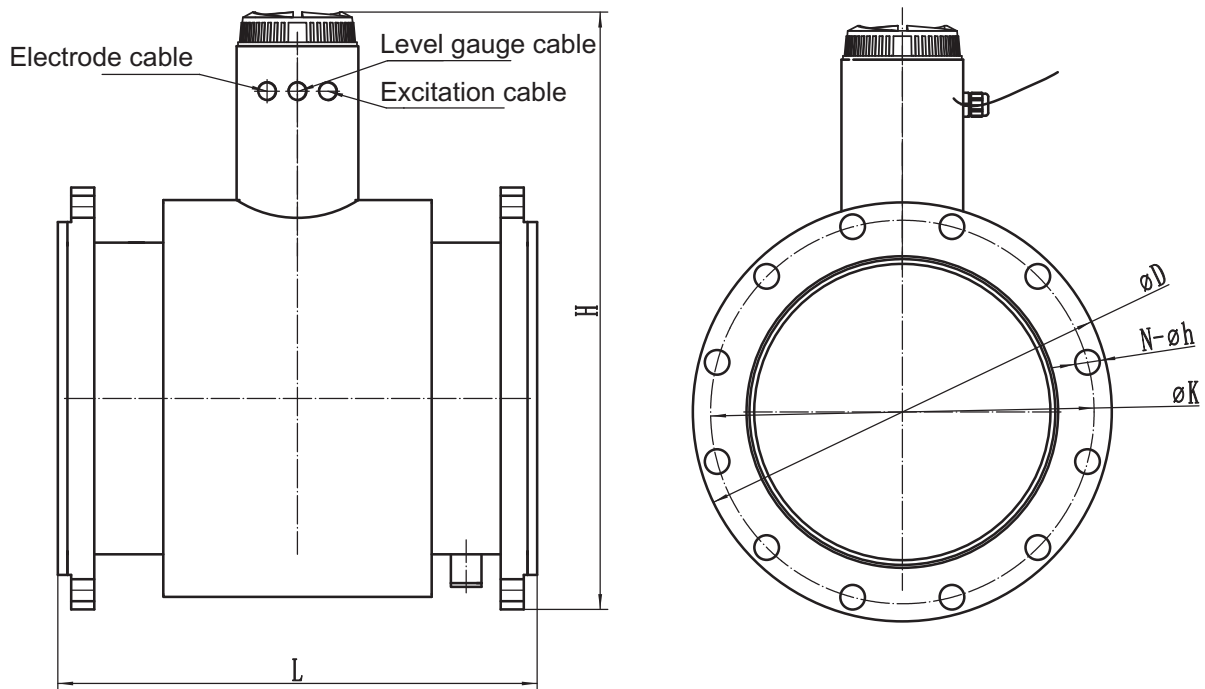

DN200-DN1000 Drawing (DIN Flange), Other flange standards are available

Diameter		Nominal pressure	L (mm)	H (mm)	ϕA (mm)	ϕK (mm)	n* ϕh (mm)
(mm)	Inch						
DN200	8"	0.6	400	494	320	280	8* $\phi 18$
DN250	10"	0.6	450	561	375	335	12* $\phi 18$
DN300	12"	0.6	500	623	440	395	12* $\phi 22$
DN350	14"	0.6	550	671	490	445	12* $\phi 22$
DN400	16"	0.6	600	708	540	495	16* $\phi 22$
DN450	18"	0.6	600	778	595	550	16* $\phi 22$
DN500	20"	0.6	600	828	645	600	20* $\phi 22$
DN600	24"	0.6	600	934	755	705	20* $\phi 22$
DN700	28"	0.6	700	1041	860	810	24* $\phi 26$
DN800	32"	0.6	800	1149	975	920	24* $\phi 30$
DN900	36"	0.6	900	1249	1075	1020	24* $\phi 30$
DN1000	40"	0.6	1000	1359	1175	1120	28* $\phi 30$



Description



ART mini magnetic flow meter is an economical option for small pipe size compared with other process connection, it includes transmitter and sensor, Which enjoy the advantages of small and compact, no moving parts, maintenance-free, save the installation space and reduce freight costs etc. The Magmeters is ideal for use in the field of mechanical engineering and plant construction. It has DN3 /DN6/DN10/DN15 size, 4-20mA, Pulse and RS485 Modbus available.



Features

- Integrated verification, diagnostic function and empty pipe detection.
- Bidirectional flow measurement.
- RS485 interface supporting up to 2km distance at 14400 bps communication.
- Programmable low frequency square wave field excitation, improving measurement stability and reducing power consumption.
- Implementing 'Rate-Of-Change Limit' technology to eliminate sharp electrical noise contained in the flow signal and stabilize the display and outputs.
- Optional real-time clock, power-failure and history data logging function, storing up to 30 days measurement records.

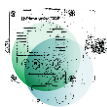

Technical Data

Size	DN3, DN6, DN10, DN15
Accuracy	±0.5% of reading at flow velocity ≥ 0.5m/s
Velocity	0.3~15 m/s
Structure	Compact
Conductivity	> 5 μS/cm, demineralized water > 20 μS/cm
Protection Grade	IP65
Electrode	SS316L, Hastelloy C, Titanium
Power Supply	85~250 Vac (45~63Hz), 16~30 Vdc
Power Consumption	<15W
Signal Output	4~20mA (load resistor 0~75Ω), Pulse (0~5K Hz)
Communicaiton	RS485 MODBUS
Ambient Temperature	-10℃~55℃
Fluid Temperature	-10℃~60℃
Sensor Material	Measuring tube: PEEK
Process connection	Thread, G1/2", 1/2"NPT, 1/2" BSP, G3/8" for DN3 and DN6 (optional)
Transmitter Material	Aluminium alloy with epoxy painting
Nominal Pressure	1.6 Mpa
Display	Instantaneous flow, total flow, flow velocity
Function	High and low alarm, empty pipe alarm, self-diagnosis
Totalizer	Three built-in totalizers: forward flow, reverse flow and net flow
Display Unit	L/s, L/m, L/h, m³/s, m³/m, m³/h, UKG, USG, gal/s, gal/m, gal/h, mass flow unit: kg/s, kg/m, kg/h,t/s, t/m, t/h
Language	English, Chinese



Dimension

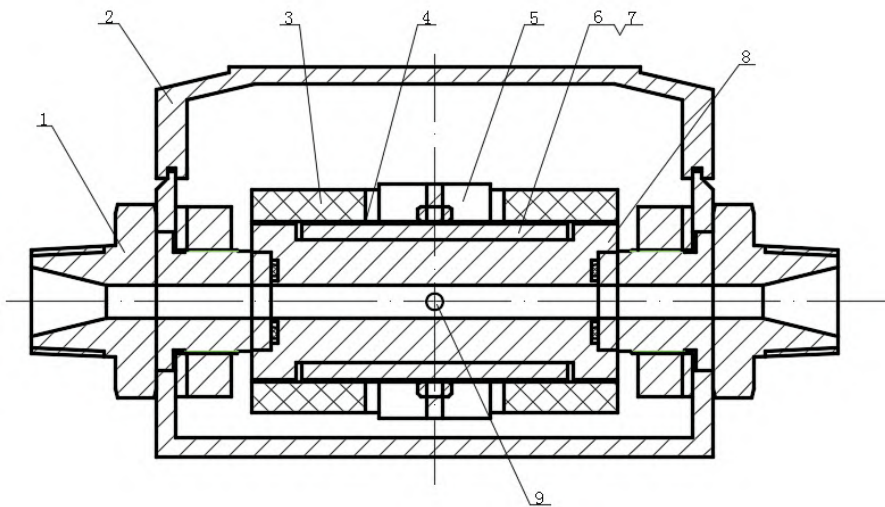
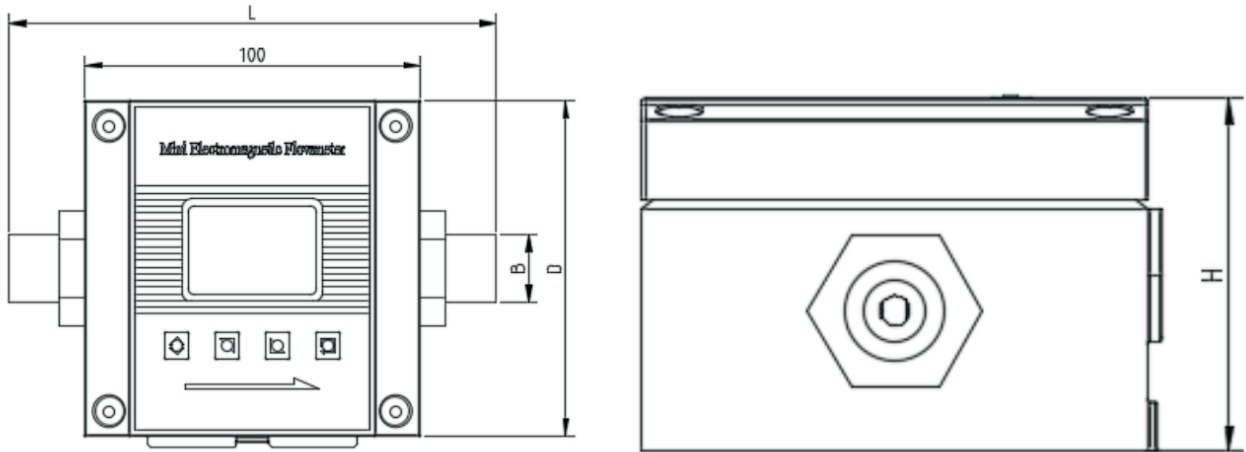

1. Connector
2. Shell
3. Excitation Coil
4. Pole Shoe
5. Magnet Yoke
6. Bracket Plate Assembly
7. Fixed Block
8. Measuring Tube
9. Electrode-assembly

Caliber		Nominal Pressure (Mpa)	Dimension			
mm	Inch		L(mm)	D(mm)	H(mm)	B(mm)
3	1/8"	1.6	135	100	70	G1/2"
6	1/4"		145			G1/2"
10	3/8"		145			G1/2"
15	1/2"		155			G1/2"

DN		Flow Range (L/min)		Male Thread
mm	Inch	Standard	Special	
3	1/8"	0.2~2	0.2~4	G1/2"
6	1/4"	0.8~8	0.8~16	G1/2"
10	3/8"	2~20	2~40	G1/2"
15	1/2"	5~50	5~100	G1/2"



The concentration ratio of slurry can reach 55%, and the variation range is usually less than 5%



Description

Noise is common in process fluids containing solid particulates, and it can influence the measurement, our slurry magnetic flow meter adopts square wave excitation and 25Hz/30Hz high excitation, which can eliminate interference between the sharp wave noise generated by solid particles, ensures accurate measurement of viscous medium.



Industries

Cement slurry, sludge, gypsum slurry, paper pulp, juice, syrup, ore slurry, coal slurry, etc.



Oil Field



Ore Slurry



Paper Pulp



Gypsum Slurry



Cement Slurry



Features

01

Special design grouting converter: Special converter can eliminate interference between the sharp wave noise generated by solid particles.

02

Medium concentration: the concentration of slurry can reach 55%, and the variation range is usually less than 5%.

03

Excitation method: square wave excitation (4 kinds of square waves) improves flow measurement stability.

04

Excitation Frequency: 25 Hz/30 Hz excitation frequency for choose. High excitation frequency has high anti-interference ability, ensures accurate measurement of viscous medium.

05

LCD backlight display: instantaneous flow, total flow, flow velocity, percentage flow, etc.



Technical Data

Size	DN3-DN3000 (1/8"-120")	
Accuracy	±0.5% of reading at flow velocity ≥ 0.5m/s	
Velocity	0.1~15 m/s	
Repeatability	≤0.17%	
Excitation current	125 mA, 187 mA, 250 mA	
Excitation Frequency	25 Hz/30 Hz	
Structure	Compact / remote, cable length 10m standard, 100m max	
Conductivity	> 5 μS/cm, demineralized water > 20 μS/cm	
Protection Grade	Transmitter: IP65 standard, IP67 optional	
	Sensor: IP65 standard, IP68 (submersible, only available for remote type)	
Electrode	SS316L, Hastelloy C, Hastelloy B, Titanium, Tantalum, Platinum-iridium	
Power Supply	85~250 VAC (50/60 Hz), 20~36 VDC	
Power Consumption	<20W	
Signal Output	Analog	4~20mA (load resistor 0~750Ω)
	Frequency	Forward & reverse flow output with a frequency range of 1~5000Hz
	Alarm	Two isolated open collector transistor (OCT) outputs for alarm signals
Communication	RS485 MODBUS standard, HART, GPRS, PROFIBUS optional	
Display	LCD Display, 128X128mm, three lines, 4 buttons	
Ambient Temperature	-20℃~60℃	
Fluid Temperature	Compact: -20℃~80℃, Remote: -20℃~120℃	
Liner Material	PTFE (-20℃~150℃, DN15-DN1600)	
	FEP (-20℃~120℃, DN15-DN1800)	
	PFA (-20℃~160℃, DN15-DN800)	
	Polyurethane (-10℃~60℃, DN40-DN1600)	
	Neoprene (-10℃~80℃, DN40-DN3000)	
	Hard Rubber (-10℃~80℃, DN 40-DN3000)	
Sensor Material	Measuring tube: SS304	
	Flange & housing: carbon steel (standard), SS304 / SS316 optional	
Transmitter Material	Aluminium alloy with epoxy painting	
Nominal Pressure	Flange	PN10 / PN16 / PN25 / PN40 DIN 10K / 20K / 30 K JIS 150# / 300# / 600# ANSI
	Insertion, tri-clamp wafer, thread	PN16
Display	Instantaneous flow, total flow, flow velocity	
Function	High and low alarm, empty pipe alarm, exciting alarm, self-diagnosis	
Totalizer	Three built-in totalizers: forward flow, reverse flow and net flow	
Display Unit	L/s, L/m, L/h, m³/s, m³/m, m³/h, UKG, USG, gal/s, gal/m, gal/h, kg/s, kg/m, kg/h, t/s, t/m, t/h	
Language	English, Chinese	



Process Connection



Compact



Remote



Tri-clamp



Thread



Wafer



Union



Dimension

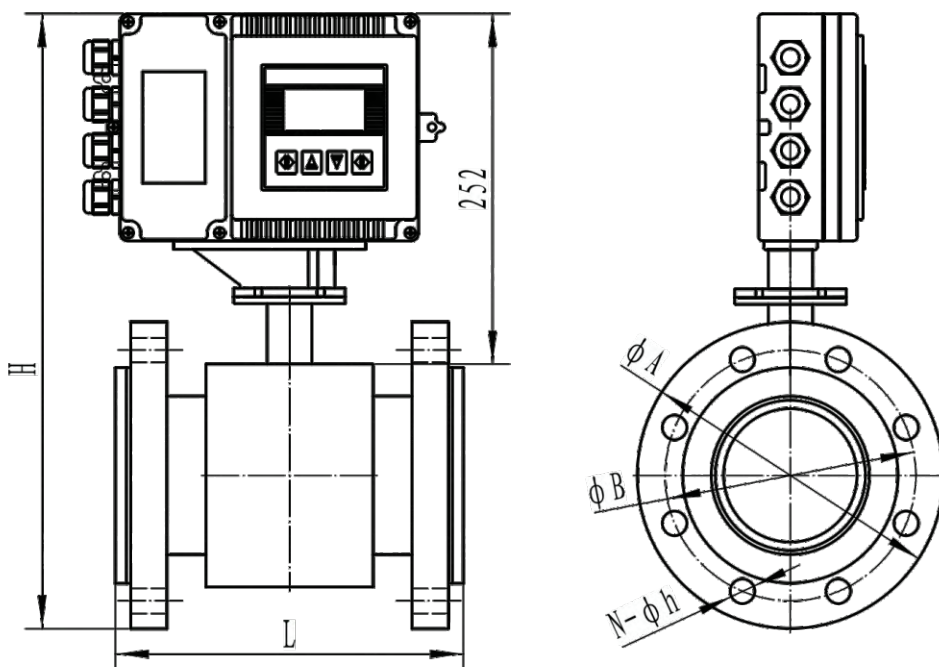

Diameter		Flange	Pressure	H(mm)	L(mm)	φA(mm)	φB(mm)	φh(mm)	N(mm)
mm	Inch								
DN15	1/2"	ANSI	150#	343	200	88.9	60.45	4	15.7
DN20	3/4"	ANSI	150#	348	200	98.6	69.85	4	15.7
DN25	1"	ANSI	150#	353	200	108	79.25	4	15.7
DN32	1¼"	ANSI	150#	358	200	117.3	88.9	4	15.7
DN40	1½"	ANSI	150#	368	200	127	98.6	4	15.7
DN50	2"	ANSI	150#	388	200	152.4	120.7	4	19.1
DN65	2½"	ANSI	150#	408	200	177.8	139.7	4	19.1
DN80	3"	ANSI	150#	423	200	190.5	152.4	4	19.1
DN100	4"	ANSI	150#	451	250	228.6	190.5	8	19.1
DN125	5"	ANSI	150#	474	250	254	215.9	8	22.4
DN150	6"	ANSI	150#	502	300	279.4	241.3	8	22.4
DN200	8"	ANSI	150#	563	350	342.9	298.5	8	22.4
DN250	10"	ANSI	150#	638	450	406.4	362	12	25.4
DN300	12"	ANSI	150#	701	500	482.6	431.8	12	25.4
DN350	14"	ANSI	150#	753	550	533.4	476.3	12	28.4
DN400	16"	ANSI	150#	809	600	596.9	539.8	16	28.4
DN450	18"	ANSI	150#	855	600	635	577.9	16	31.75
DN500	20"	ANSI	150#	912	600	698.5	635	20	31.75
DN600	24"	ANSI	150#	1024	600	812.8	749.3	20	35.1

ART Reduced Bore Electromagnetic Flow Meter



Description

ART reduced bore electromagnetic flow meter is ideal for these applications with zero upstream or downstream piping as they can better handle distorted velocity flow profiles arising from the pipe networks, allowing total flexibility in installation for demanding applications compared with full bore magnetic flow meter. It can increase velocity and flow if it's low flow.



Industries

Textile Processing Industries	Effluent Treatment Plant	Sewage Treatment Plant Water Supply Scheme
Steel & Aluminum Industries	Food & Drug Industries	Chemical & Fertilizer Industries



Applications



Features

01

No need straight pipe in the upstream and downstream.

02

It can increase velocity and flow if it's low flow.

03

Self-diagnosis, empty pipe alarm, exciting alarm, high and low flow alarm.

04

Measure forward flow, reverse flow and net flow.

05

It has multiple output signals for choose, 4~20 mA+Pulse + RS485 Modbus are standard signal, HART, Profibus, GPRS are optional.



Battery reduced bore



Compact reduced bore



Remote reduced bore



Technical Data

Size	DN50-DN300 (2"-12")	
Sensor	Reduced bore, U0+D0, don't need any straight pipe in the upstream and downstream	
Accuracy	$\pm 0.5\%$ of reading at flow velocity $\geq 0.5\text{m/s}$, $\pm 0.2\%$ optional at flow velocity $\geq 0.5\text{m/s}$	
Velocity	0.1~15 m/s	
Repeatability	$\leq 0.17\%$	
Structure	Compact / remote, cable length 10m standard, 100m max	
Conductivity	$> 5 \mu\text{S/cm}$, demineralized water $> 20 \mu\text{S/cm}$	
Protection Grade	Transmitter: IP65 standard, IP67 optional	
	Sensor: IP65 standard, IP68 (submersible, only available for remote type)	
Electrode	SS316L, Hastelloy C, Hastelloy B, Titanium, Tantalum, Platinum-iridium	
Power Supply	85~250 VAC (50/60 Hz), 8~36 VDC, 3.6V lithium battery	
Power Consumption	$< 20\text{W}$	
Signal Output	Analog	4~20mA (load resistor 0~750 Ω)
	Frequency	Forward & reverse flow output with a frequency range of 1~5000Hz
	Alarm	Two isolated open collector transistor (OCT) outputs for alarm signals
Communication	RS485 MODBUS standard, HART, GPRS, PROFIBUS optional	
Display	LCD Display, 128X128mm, three lines, 4 buttons	
Ambient Temperature	$-20^{\circ}\text{C} \sim 60^{\circ}\text{C}$	
Fluid Temperature	Compact: $-20^{\circ}\text{C} \sim 80^{\circ}\text{C}$, Remote: $-20^{\circ}\text{C} \sim 120^{\circ}\text{C}$	
Liner Material	Neoprene, hard rubber	
Process connection	Flange	
Sensor Material	Measuring tube: SS304	
	Flange & housing: carbon steel (standard), SS304 / SS316 optional	
Transmitter Material	Aluminium alloy with epoxy painting	
Display	Instantaneous flow, total flow, flow velocity	
Function	High and low alarm, empty pipe alarm, exciting alarm, self-diagnosis	
Totalizer	Three built-in totalizers: forward flow, reverse flow and net flow	
Display Unit	L/s, L/m, L/h, m^3/s , m^3/m , m^3/h , UKG, USG, gal/s, gal/m, gal/h, kg/s, kg/m, kg/h, t/s, t/m, t/h	
Language	English, Chinese, Italian, Portuguese, French, Spanish, Korean	



Dimension

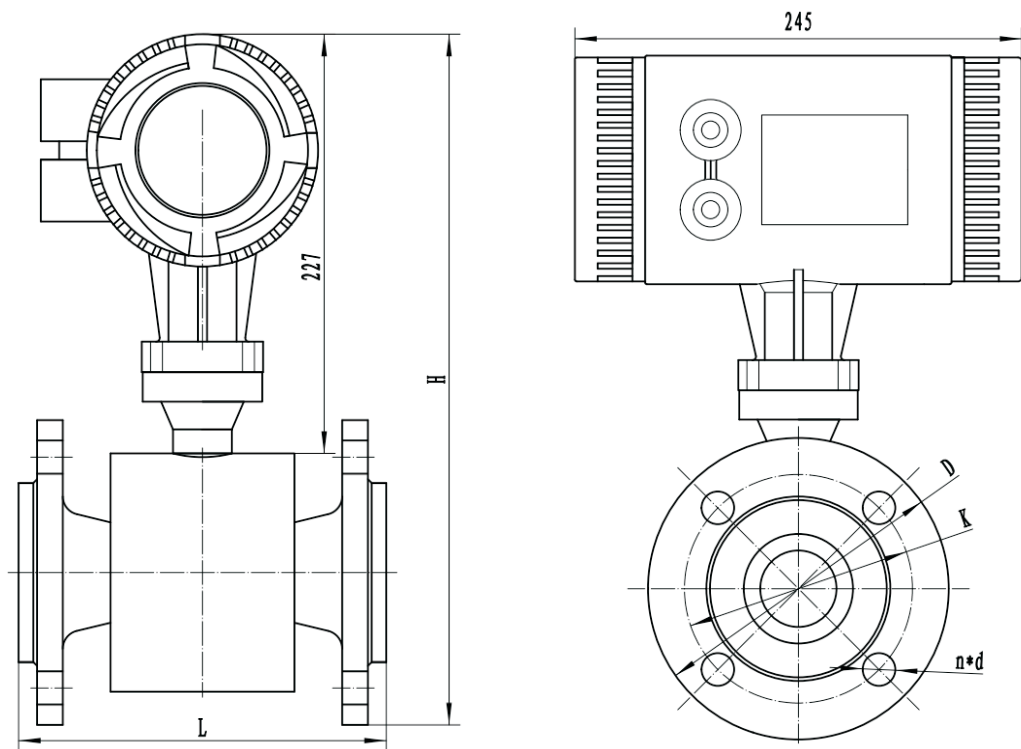

DN50-DN300 Compact Reduced Bore Magnetic Flow Meter DIN PN16 Drawing

Size		Flange	Nominal Pressure (MPa)	L (mm)	D (mm)	H (mm)	K (mm)	n*d (mm)
mm	Inch							
DN50	2"	DIN	1.6	200	165	374	125	4*φ18
DN65	2½"	DIN	1.6	200	185	377	145	4*φ18
DN80	3"	DIN	1.6	200	200	392	160	8*φ18
DN100	4"	DIN	1.6	250	220	419	180	8*φ18
DN125	5"	DIN	1.6	250	250	434	210	8*φ19
DN150	6"	DIN	1.6	300	285	462	240	8*φ22
DN200	8"	DIN	1.6	350	340	504	295	12*φ22
DN250	10"	DIN	1.6	450	405	567	355	12*φ26
DN300	12"	DIN	1.0	500	445	630	400	12*φ22
		DIN	1.6	500	460	638	410	12*φ26



Dimension

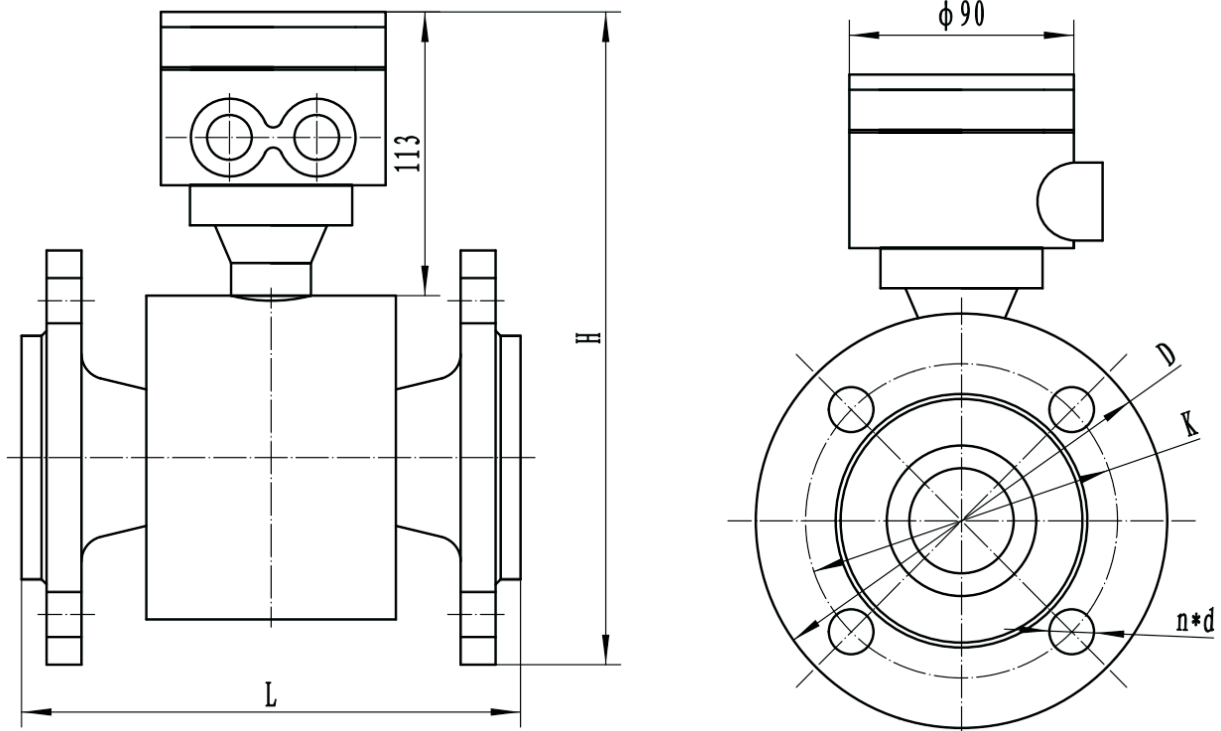

DN50-DN300 Remote Reduced Bore Magnetic Flow Meter DIN PN16 Drawing

Size		Flange	Nominal Pressure (MPa)	L (mm)	D (mm)	H (mm)	K (mm)	n*d (mm)
mm	Inch							
DN50	2"	DIN	1.6	200	165	260	125	4* ϕ 18
DN65	2½"	DIN	1.6	200	185	263	145	4* ϕ 18
DN80	3"	DIN	1.6	200	200	278	160	8* ϕ 18
DN100	4"	DIN	1.6	250	220	305	180	8* ϕ 18
DN125	5"	DIN	1.6	250	250	320	210	8* ϕ 19
DN150	6"	DIN	1.6	300	285	348	240	8* ϕ 22
DN200	8"	DIN	1.6	350	340	390	295	12* ϕ 22
DN250	10"	DIN	1.6	450	405	453	355	12* ϕ 26
DN300	12"	DIN	1.0	500	445	516	400	12* ϕ 22
		DIN	1.6	500	460	524	410	12* ϕ 26

